

### FEATURES

- Primary-side sensing and regulation without TL431 and opto-coupler
- High precision constant voltage and current regulation at universal AC input
- Multi-mode PWM/PFM operation for efficiency improving
- Good dynamic response
- Programmable CV and CC regulation
- Built-in line voltage and primary winding inductance compensation
- Programmable cable drop compensation
- No need for control loop compensation
- Audio noise free operation
- Internal BJT switch
- Built-in leading edge blanking (LEB)
- Comprehensive protection coverage with auto-recovery
  - VDD over voltage protection
  - VDD under voltage lockout with hysteresis (UVLO)
  - Cycle-by-cycle current limiting
  - Feedback loop open protection
  - Output short circuit protection
  - Over temperature protection (OTP)

### APPLICATIONS

Low Power AC/DC offline SMPS for

- Cell Phone Charger
- Digital Cameras Charger
- Small Power Adaptor
- Auxiliary Power for PC, TV etc.
- Linear Regulator/RCC Replacement

### TYPICAL APPLICATION

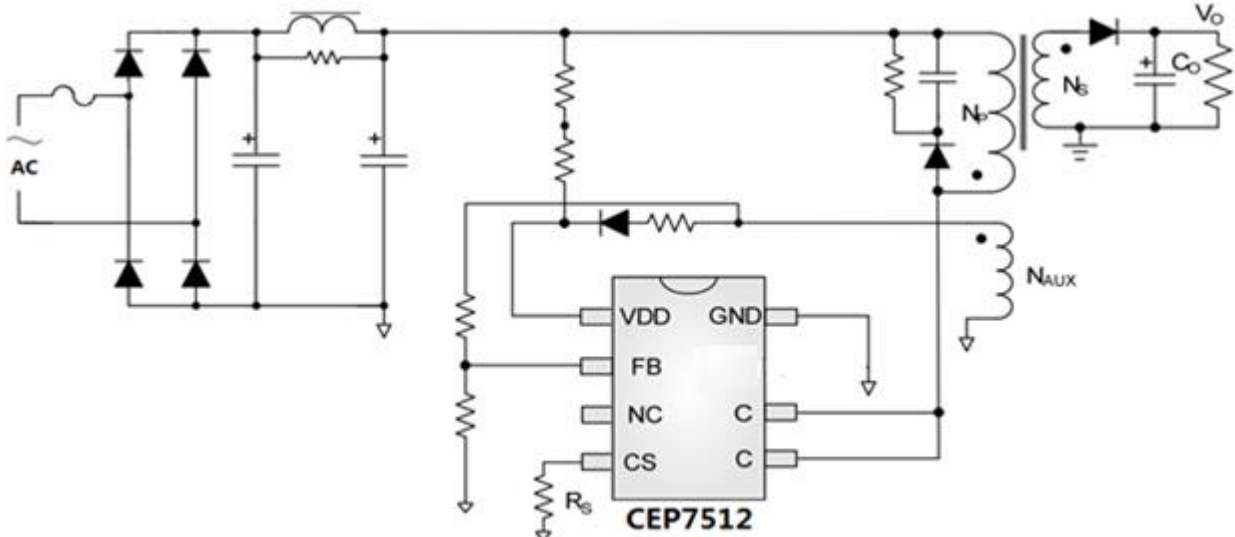

### GENERAL DESCRIPTION

CEP7512 is a high performance offline PSR power switch for low power AC/DC charger and adapter applications. It operates in primary-side sensing and regulation. Consequently, opto-coupler and TL431 could be eliminated. Proprietary Constant Voltage (CV) and Constant Current (CC) control is integrated as shown in the figure below.

In CC control, the current and output power setting can be adjusted externally by the sense resistor  $R_s$  at CS pin. In CV control, multi-mode operations are utilized to achieve high performance and high efficiency. In addition, good load regulation is achieved by the built-in cable drop compensation. Device operates in PFM in CC mode as well at large load condition and it operates in PWM with frequency reduction at light/medium load. The chip consumes very low operation current, it can achieve less than 75mW standby power. CEP7512 offers comprehensive protection coverage with auto-recovery features including Cycle-by-Cycle current limiting, VDD over voltage protection, short circuit protection, built-in leading edge blanking, VDD under voltage lockout (UVLO), OTP etc. CEP7512 is offered in SOP7 package.

### Typical CC/CV Curve

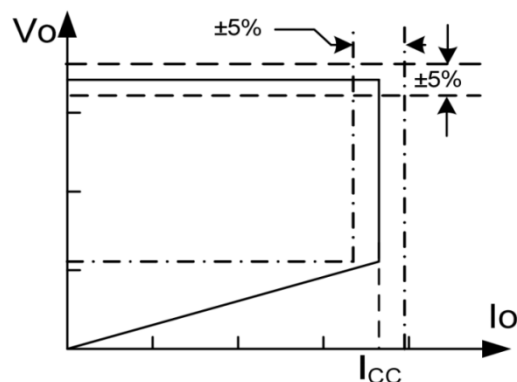
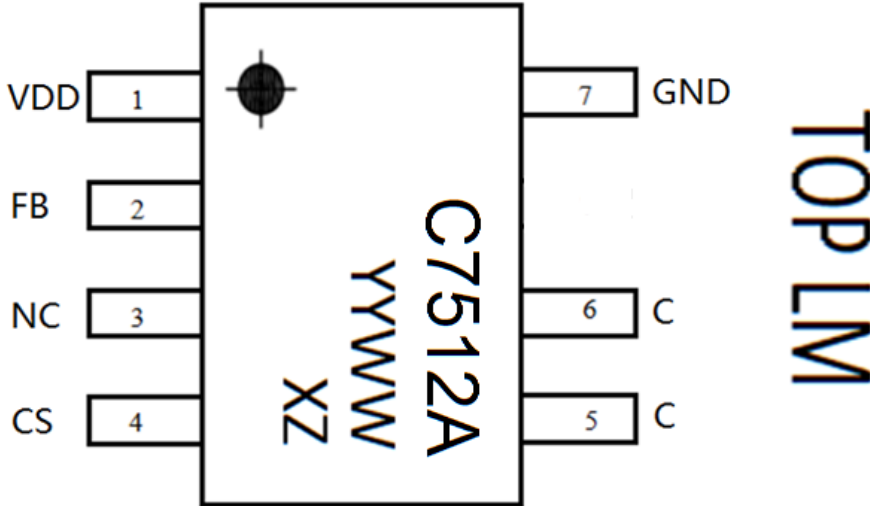

Fig.1. Typical CC/CV Curve

## ORDERING INFORMATION

| PART NUMBER | Min/Max Storage Temperature | PACKAGE | PINS | PACKING     |
|-------------|-----------------------------|---------|------|-------------|
| CEP7512ASP7 | -55°C to 150°C              | SOP-7   | 7    | TAPE & REEL |

## PIN Configuration AND Marking Information



**C7512A** : Product Number

**YYWW** : Date Code

**XZ** : Factory code

## PIN DESCRIPTIONS

| Pin No. | NAME | Description  |
|---------|------|--|
| 1       | VDD  | Power Supply   |
| 2       | FB   | The voltage feedback from auxiliary winding. Connected to resistor divider from auxiliary winding reflecting output voltage. |
| 3       | NC   |  |
| 4       | CS   | Input Pin. Current sense.  |
| 5/6     | C    | HV BJT collector pin.  |
| 7/8     | GND  | Ground   |

**FUNCTIONAL BLOCK DIAGRAM**

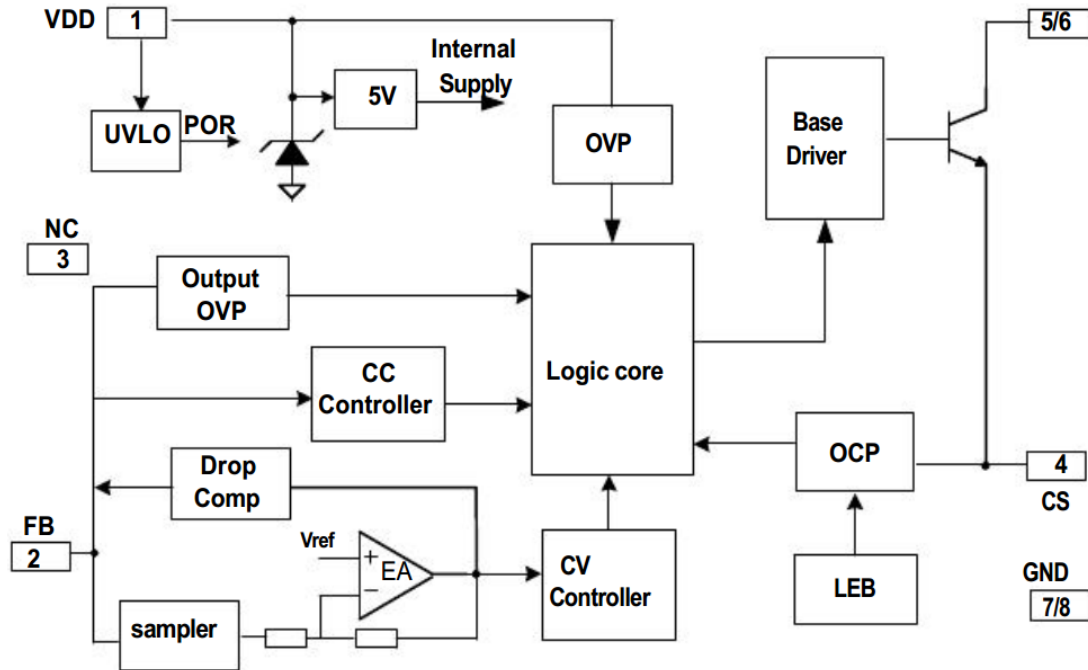

**ABSOLUTE MAXIMUM RATINGS**

| Parameter   | Rating     | Unit |
|---|------------|------|
| C-B Voltage   | 800        | V    |
| VDD Voltage   | -0.3 to 30 | V    |
| CS Input Voltage                                      | -0.3 to 7  | V    |
| FB Input Voltage                                      | -0.3 to 7  | V    |
| Min/Max Operating Junction Temperature T <sub>J</sub> | -40 to 150 | °C   |
| Lead Temperature (Soldering 10 sec.)                  | 260        | °C   |

Note: Do not exceed these limits to prevent damage to the device. Exposure to absolute maximum rating conditions for long periods may affect device reliability.

## ELECTRICAL CHARACTERISTICS

CEP7512ASP7 (TA = 25°C, VDD=15V, if not otherwise noted)

| Symbol                                  | Parameter                                  | Test Conditions                         | Min        | Typ   | Max   | Unit |
|---|--|---|------------|-------|-------|------|
| <b>Supply Voltage (VDD) Section</b>     |  |   |            |       |       |      |
| I <sub>start-up</sub>                   | Start up current                           | VDD=UVLO_OFF-1V                         |            | 5     | 15    | uA   |
| I <sub>static</sub>                     | Static current                             |   |            | 0.72  | 1.0   | mA   |
| UVLO(OFF)                               | VDD under voltage lockout exit             |   | 18.4       | 19.4  | 20.4  | V    |
| UVLO(ON)                                | VDD under voltage lockout enter            |   | 6.5        | 7.1   | 7.8   | V    |
| VDD_OVP                                 | VDD over voltage protection                |   | 26.5       | 28.0  | 29.5  | V    |
| VDD_max                                 | Max. Operating Voltage                     |   |            |       | 26    | V    |
| <b>Current Sense Input Section</b>      |  |   |            |       |       |      |
| TLEB                                    | LEB time                                   |   |            | 0.5   |       | us   |
| V <sub>th_ocp_min</sub>                 | Minimum over current threshold             |   | 485        | 500   | 515   | mV   |
| V <sub>th_ocp_max</sub>                 | Maximum over current threshold             |   |            | 555   |       | mV   |
| V <sub>cs_mini</sub>                    | Minimum CS threshold                       |   |            | 100   |       | mV   |
| T <sub>on_max</sub>                     | Maximum Ton                                |   |            | 50    |       | us   |
| T <sub>d_oc</sub>                       | OCP propagation delay                      |   |            | 100   |       | ns   |
| <b>FB Input Section</b>                 |  |   |            |       |       |      |
| V <sub>ref_fb</sub>                     | Reference voltage for feedback threshold   |   | 2.475      | 2.500 | 2.525 | V    |
| T <sub>pause_min</sub>                  | Minimum Toff                               |   |            | 2.0   |       | us   |
| F <sub>min</sub>                        | Minimum frequency                          |   | 720        | 800   | 880   | Hz   |
| I <sub>comp_cable</sub>                 | Maximum cable compensation current         |   |            | 48    |       | uA   |
| <b>Output Over Voltage Protection</b>   |  |   |            |       |       |      |
| V <sub>OVP</sub>                        | Output Over voltage threshold              |   | 2.85       | 3.00  | 3.15  | V    |
| <b>On chip Over temperature Section</b> |  |   |            |       |       |      |
| T <sub>otp</sub>                        | Over temperature protection trigger point  |   |            | 165   |       | °C   |
| T <sub>otp_rec</sub>                    | Over temperature protection recovery point |   |            | 130   |       | °C   |
| <b>Power BJT Section</b>                |  |   |            |       |       |      |
| V <sub>ceo</sub>                        | Collector-emitter breakdown voltage        | I <sub>c</sub> =10mA, I <sub>b</sub> =0 | 450        |       |       | V    |
| V <sub>cbo</sub>                        | Collector-base breakdown voltage           | I <sub>c</sub> =10mA                    | <b>800</b> |       |       | V    |
| I <sub>c</sub>                          | Collect Peak Current                       |   |            | 0.8   |       | A    |

**CHARACTERIZATION PLOTS**

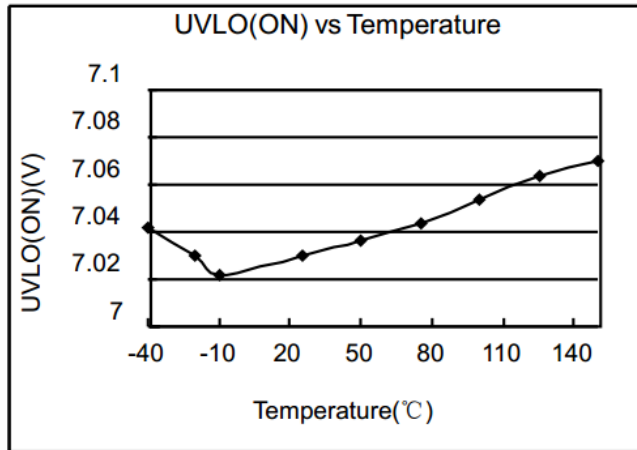
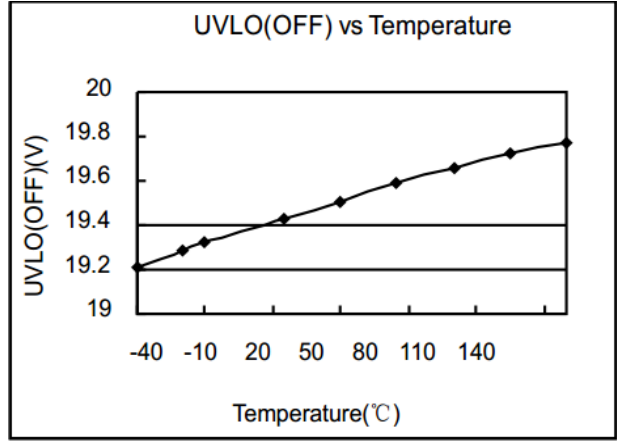
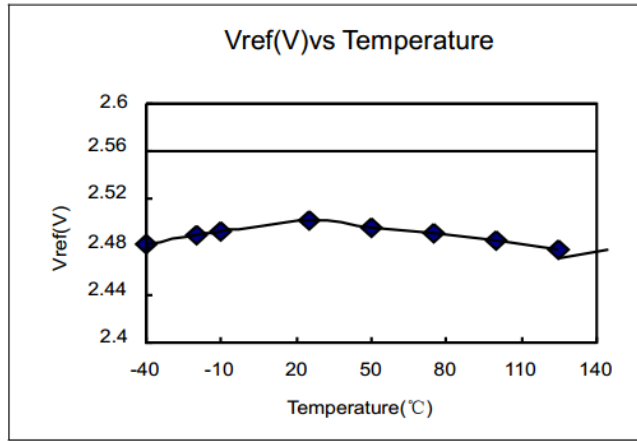
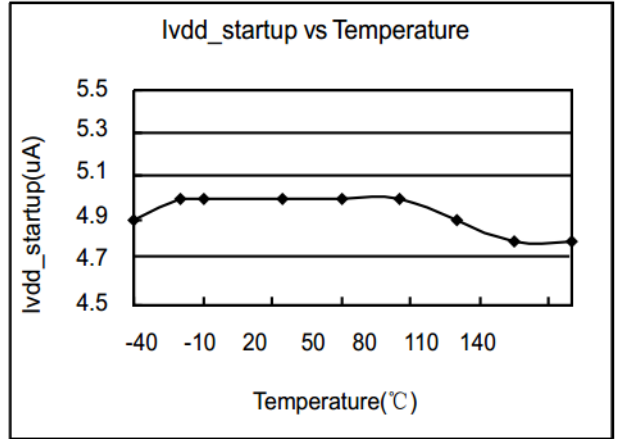
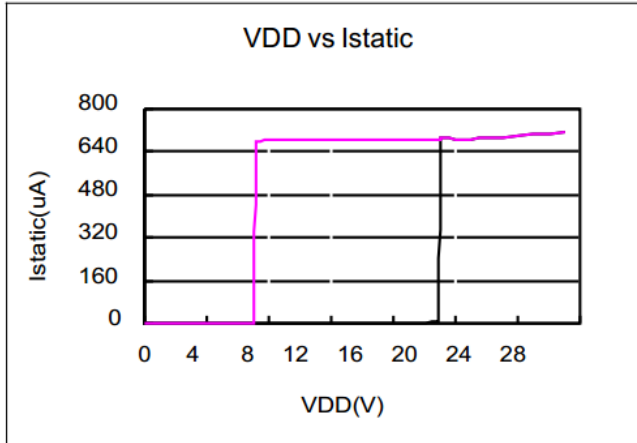

## OPERATION DESCRIPTION

CEP7512 is a cost effective PSR power switch optimized for off-line low power AC/DC applications including battery chargers and adaptors. It operates in primary side sensing and regulation, thus opto-coupler and TL431 are not required. Proprietary built-in CV and CC control can achieve high precision CC/CV control meeting most adaptor and charger application requirements.

### ➤ Startup Current and Start up Control

Startup current of CEP7512 is designed to be very low so that VDD could be charged up above UVLO threshold and starts up quickly. A large value startup resistor can therefore be used to minimize the power loss in application.

### ➤ Operating Current

The Operating current of CEP7512 is as low as 720uA. Good efficiency is achieved with the low operating current together with 'Muti-mode' control features.

### ➤ CC/CV Operation

CEP7512 is designed to produce good CC/CV control characteristic as shown in the Fig. 1. In charger applications, a discharged battery charging starts in the CC portion of the curve until it is nearly full charged and smoothly switches to operate in CV portion of the curve. In an AC/DC adapter, the normal operation occurs only on the CV portion of the curve. The CC portion provides output current limiting. In CV operation, the output voltage is regulated through the primary side control. In CC operation mode, CEP7512 will regulate the output current constant regardless of the output voltage drop.

### ➤ Principle of Operation

To support CEP7512 proprietary CC/CV control, system needs to be designed in DCM mode for flyback system (Refer to Typical Application Diagram on page1). In the DCM flyback converter, the output voltage can be sensed via the auxiliary winding. During BJT turn-on time, the load current is supplied from the output filter capacitor. The current in the primary winding ramps up. When BJT turns off, the energy stored in the primary winding is transferred to the secondary side such that the current in the secondary winding is

$$I_S = \frac{N_P}{N_S} \times I_P \quad (1)$$

The auxiliary voltage reflects the output voltage as shown in fig.2 and it is given by

$$V_{AUX} = \frac{N_{AUX}}{N_S} \times (V_O + \Delta V) \quad (2)$$

Where  $\Delta V$  indicates the drop voltage of the output Diode.

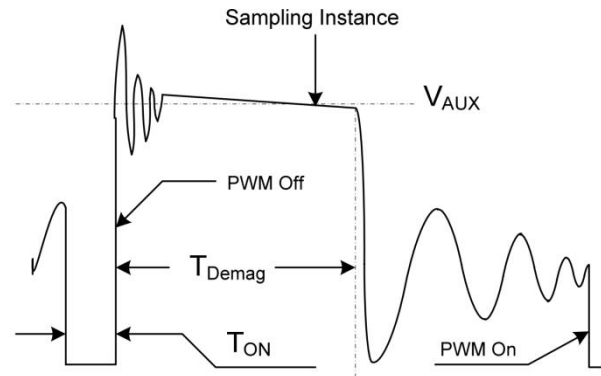

Fig.2. Auxiliary voltage waveform

Via a resistor divider connected between the auxiliary winding and FB (pin 2), the auxiliary voltage is sampled at the middle of the de-magnetization and it is hold until the next sampling. The sampled voltage is compared with Vref (typical 2.5V) and the error is amplified. The error amplifier output reflects the load condition and controls the switching off time to regulate the output voltage, thus constant output voltage can be achieved. When sampled voltage is below Vref and the error amplifier output reaches its minimum, the switching frequency is controlled by the sampled voltage to regulate the output current, thus the constant output current can be achieved.

### ➤ Adjustable CC point and Output Power

In CEP7512, the CC point and maximum output power can be externally adjusted by external current sense resistor Rs at CS pin as illustrated in Typical Application Diagram. The larger Rs, the smaller CC point is, and the smaller output power becomes, and vice versa as shown in Fig.3.

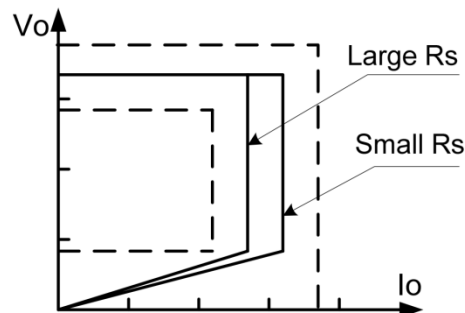

Fig.3 Adjustable output power by changing Rs

### ➤ On Time OCP Compensation

The variation of max output current in CC mode can be rather large if no compensation is provided. The OCP threshold value is self adjusted higher at higher AC voltage. This OCP threshold slope adjustment helps to compensate the increased output current limit at higher AC voltage. In CEP7512, a proprietary OCP compensation block is integrated and no external components are needed. The OCP threshold in CEP7512 is a function of the switching ON time. For the ON time less than 3.7us (typical),

the OCP threshold changes linearly from 500mV(typical) to 555mV(typical). For the ON time larger than 3.7us (typical), the OCP threshold is clamped to 555mV (typical), as shown in Figure 4.

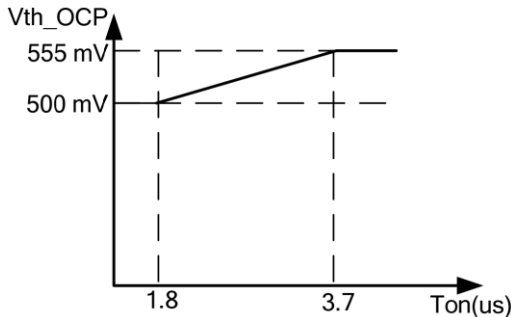

Figure.4 On time OCP compensation

### ➤ Operation switching frequency

The switching frequency of CEP7512 is adaptively controlled according to the load conditions and the operation modes.

For flyback operating in DCM, The maximum output power is given by

$$P_{O_{MAX}} = \frac{1}{2} L_P F_{SW} I_P^2 \quad (3)$$

Where  $L_P$  indicate the inductance of primary winding and  $I_P$  is the peak current of primary winding.

Refer to the equation 3, the change of the primary winding inductance results in the change of the maximum output power and the constant output current in CC mode. To compensate the change from variations of primary winding inductance, the switching frequency is locked by an internal loop such that the switching frequency is

$$F_{SW} = \frac{1}{2T_{Demag}} \quad (4)$$

Since  $T_{Demag}$  is inversely proportional to the inductance, as a result, the product  $L_P$  and  $f_{sw}$  is constant, thus the maximum output power and constant current in CC mode will not change as primary winding inductance changes. Up to +/-7% variation of the primary winding inductance can be compensated.

### ➤ Current Sensing and Leading Edge Blanking

Cycle-by-Cycle current limiting is offered in CEP7512. The switch current is detected by a sense resistor into the CS pin. An internal leading edge blanking circuit chops off the sensed voltage spike at initial internal power BJT on state so that the external RC filtering on sense input is no longer needed.

### ➤ Programmable Cable drop Compensation

In CEP7512, cable drop compensation is implemented to achieve good load regulation. An offset voltage is generated at FB by an internal current flowing into the resistor divider. The current is

proportional to the switching off time, as a result, it is inversely proportional to the output load current, thus the drop due to the cable loss can be compensated. As the load current decreases from full-load to no-load, the offset voltage at FB will increase. It can also be programmed by adjusting the resistance of the divider to compensate the drop for various cable lines used.

The percentage of maximum compensation is

$$\frac{\Delta V}{V_{out}} = \frac{I_{comp\_cable} \times R1 // R2 \times 10^{-6}}{2.5} \times 100\% \quad (5)$$

$V$  is load compensation voltage and  $V_{out}$  is output voltage; For example:  $R1//R2=6.2Kohm$ , the percentage of maximum compensation is

$$\frac{\Delta V}{V_{out}} = \frac{48 \times 6200 \times 10^{-6}}{2.5} \times 100\% = 11.9\%$$

(6)

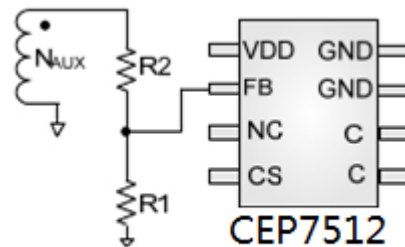

### ➤ Protection Control

Good power supply system reliability is achieved with its rich protection features including Cycle-by-Cycle current limiting (OCP), Output over voltage protection, VDD over voltage protection, short circuit protection, Under Voltage Lockout on VDD(UVLO) and over temperature protection (OTP). VDD is supplied by transformer auxiliary winding output. The output of CEP7512 is shut down when VDD drops below UVLO(ON) and the power converter enters power on start-up sequence thereafter.

To prevent the circuit being damaged under abnormal conditions, CEP7512 provides over thermal protection function. When the die temperature rises above over temperature threshold  $T_{otp}$ , the CEP7512 will shut down the base output and then latch the power supply off.

The controller will remains latched until the die temperature drops below the recovery threshold  $T_{otp\_rec}$  and the CEP7512 will reset at the same time.

**TAPE AND REEL INFORMATION**

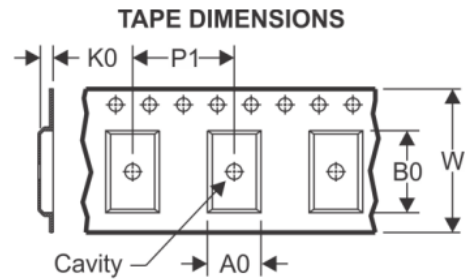
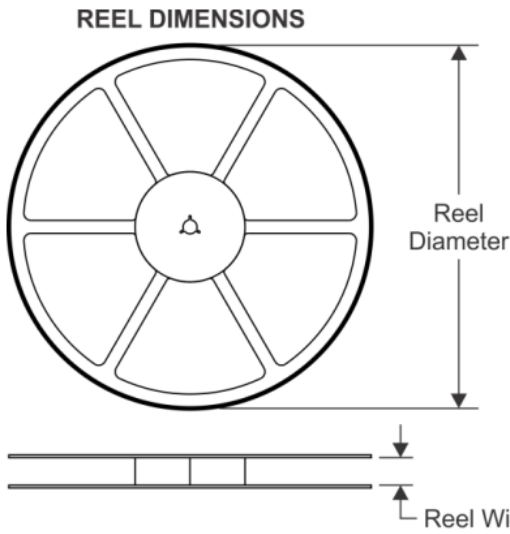

|    |   |
|----|---|
| A0 | Dimension designed to accommodate the component width     |
| B0 | Dimension designed to accommodate the component length    |
| K0 | Dimension designed to accommodate the component thickness |
| W  | Overall width of the carrier tape                         |
| P1 | Pitch between successive cavity centers                   |

**QUADRANT ASSIGNMENTS FOR PIN 1 ORIENTATION IN TAPE**

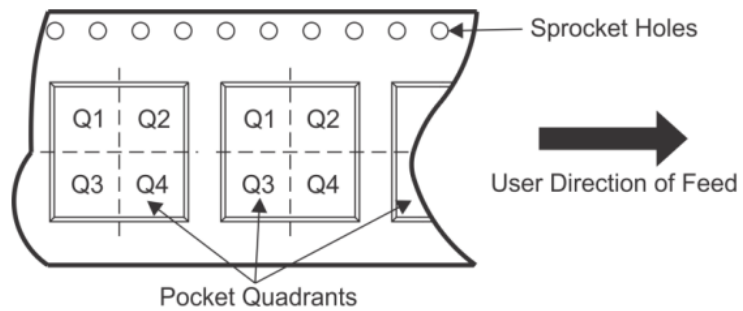

\*All dimensions are nominal

| Device     | Package Type | Package Drawing | Pins | SPQ  | Reel Diameter (mm) | Reel Width W1 (mm) | A0 (mm) | B0 (mm) | K0 (mm) | P1 (mm) | W (mm) | Pin1 Quadrant |
|------------|--------------|-----------------|------|------|--------------------|--------------------|---------|---------|---------|---------|--------|---------------|
| CEP7512SP8 | SOP-8        | C7512           | 8    | 2500 | 330.0              | 12.8               | 6.4     | 5.2     | 2.5     | 8.0     | 12.0   | Q1            |



**PACKAGE OUTLINE**

SOP-8(SOP-7 covered) PACKAGE OUTLINE AND DIMENSIONS

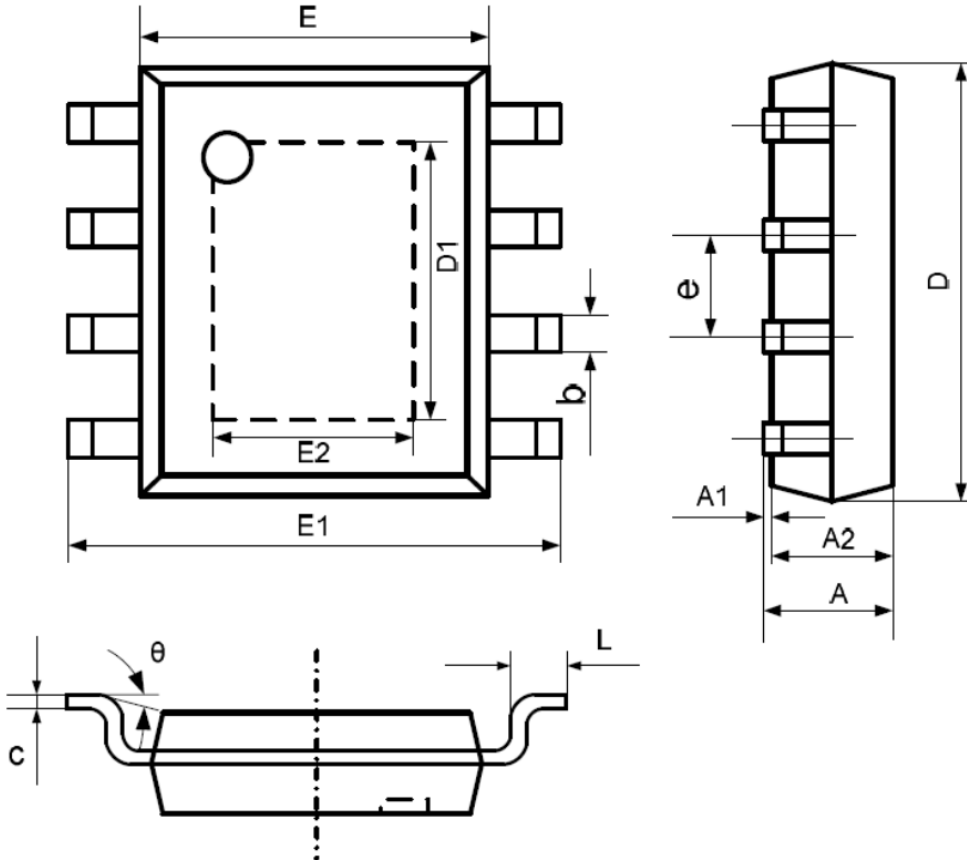

| SYMBOL | DIMENSION IN MILLIMETERS |       | DIMENSION IN INCHES |       |
|--------|--------------------------|-------|---------------------|-------|
|        | MIN                      | MAX   | MIN                 | MAX   |
| A      | 1.350                    | 1.700 | 0.053               | 0.067 |
| A1     | 0.000                    | 0.100 | 0.000               | 0.004 |
| A2     | 1.350                    | 1.550 | 0.053               | 0.061 |
| b      | 0.330                    | 0.510 | 0.013               | 0.020 |
| c      | 0.170                    | 0.250 | 0.007               | 0.010 |
| D      | 4.700                    | 5.100 | 0.185               | 0.200 |
| E      | 3.800                    | 4.000 | 0.150               | 0.157 |
| E1     | 5.800                    | 6.200 | 0.228               | 0.244 |
| e      | 1.270 TYP                |       | 0.050 TYP           |       |
| L      | 0.400                    | 1.270 | 0.016               | 0.050 |
| θ      | 0°                       | 8°    | 0°                  | 8°    |